



Solenoid valve 2/2 way N.C. With piston pilot control

21YW4K0T130

÷

21YW6K0T250

PRESENTATION:

S.V. with pilot control for interception of fluids compatible with the construction materials.

A minimum operational pressure of 0,9 bar is required.

The materials used and the tests carried out ensure maximum reliability and duration.

USE: Hot water, Steam

PIPES: G 1/2 - G 1

COILS: 8W - Ø 13
BDF - BDV 180°C (class H)

MOULDING AND BOBBIN ARE MADE BY 100% VIRGIN MATERIAL.

Max. allowable pressure (PS) 25 bar
Ambient temperature: - 40°C + 80°C



Gaskets	Temperature		Medium
T=PTFE (polytetrafluorethylen)	- 40°C	+180°C	Steam, hot water

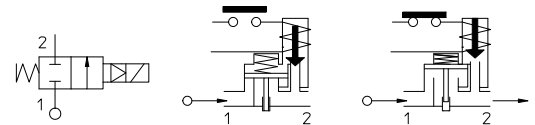

Pipe ISO 228/1	Code	Max viscosity		Ø mm	Kv l/mn	Power (watt)	Pressure		
		cSt	°E				min bar	M.O.P.D. AC bar DC bar	
G 1/2	21YW4K0T130	-	-	13	50	8	0,9	10	10
G 3/4	21YW5K0T190			19	90				
G 1	21YW6K0T250			25	160				

The "ODE" reserves the right to carry out technical and aesthetic modifications without prior notification.

MATERIALS:

Body	Brass - UNI EN 12165 CW617N
Armature tube	Stainless steel AISI series 300
Fixed core	Stainless steel AISI series 400
Plunger	Stainless steel AISI series 400
Phase displacement ring	Copper - Cu 99,9%
Spring	Stainless steel AISI series 300
Piston seal	Modified PTFE
Main seal	Glassfiber reinforced T=PTFE
Pilot seal	PTFE
Orifice	Brass - UNI EN 12165 CW617N

On request:

Connector	Pg 9 o Pg 11
Connector conformity	ISO 4400

FEATURES:

Electrical conformity	IEC 335
Protection degree	IP 67 EN 60529 (DIN 40050) with coil fitted by connector dedicated

SPARE PARTS:

1. Coil: See coils list	6. Complete piston: G 1/2 Code R452604 G 3/4 Code R452547 G 1 Code R452548
2. Complete plunger: Code R450897	7. Gasket plug: G 1/2 Code R452609 G 3/4+G 1 Code R452553
3. Complete armature tube: Code R450606	
4. Sealing ring: G 1/2 Code R452607 G 3/4 Code R452551 G 1 Code R452552	
5. Gasket cover: G 1/2 Code R452608 G 3/4+G 1 Code R450858	

KIT:

KT130K T30-AGP=2+3

MAINTENANCE KIT:

G 1/2 KTPYW4K0T13=2+4+5+6+7
G 3/4 KTPYW5K0T19=2+4+5+6+7
G 1 KTPYW6K0T25=2+4+5+6+7

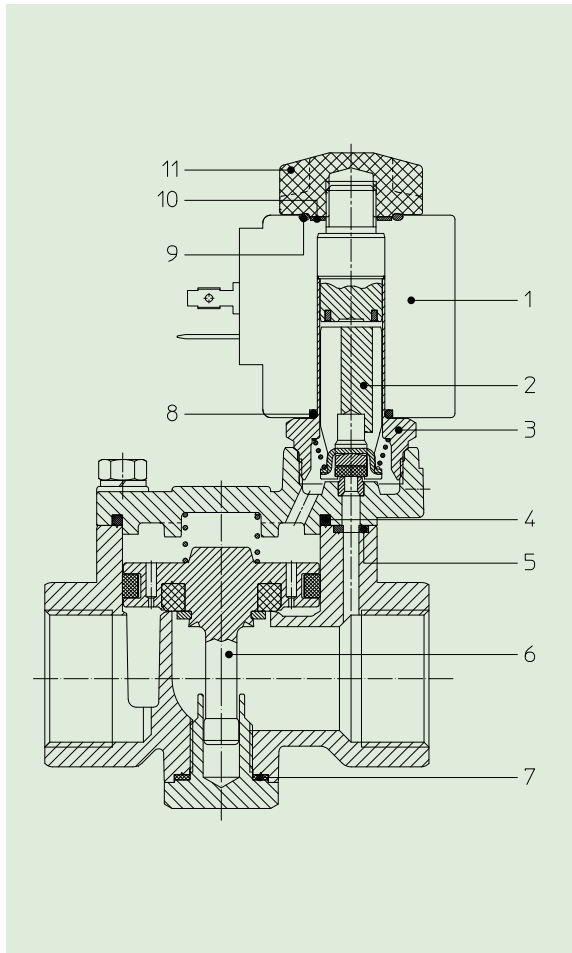

DIMENSIONS:

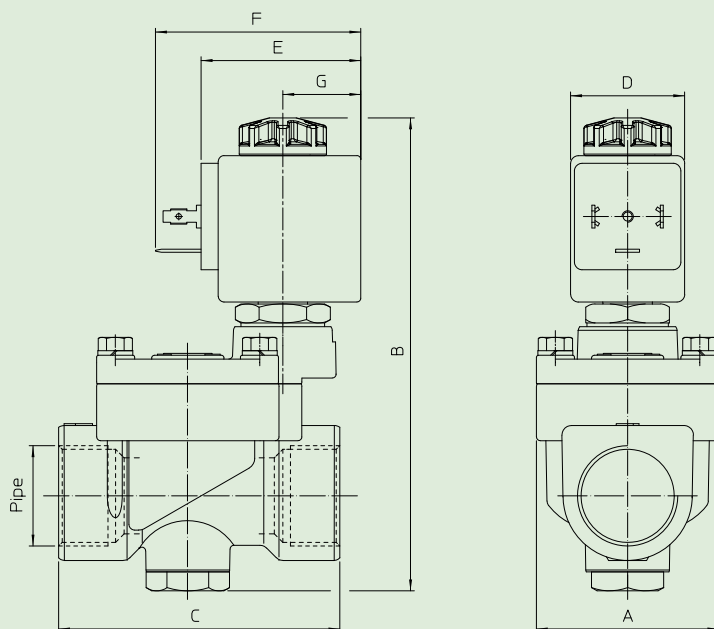

Type	Pipe ISO 228/1	A mm	B mm	C mm
21YW4K0T130	G 1/2	40	114	65
21YW5K0T190	G 3/4	48	127	74
21YW6K0T250	G 1	62	137	93

COIL TYPE	POWER ABSORPTION	DIMENSIONS			
	W	D mm	E mm	F mm	G mm
B	8	30	42	54	20,5



Solenoid valve 2/2 way N.C. With piston pilot control

21YN4K0T130-YW

÷

21YN6K0T250-YW

PRESENTATION:

S.V. with pilot control for interception of fluids compatible with the construction materials.

A minimum operational pressure of 0,9 bar is required.

The materials used and the tests carried out ensure maximum reliability and duration.

USE: Hot water, Steam

PIPES: 1/2 NPT - 1 NPT

COIL: 8W - Ø 13
BDF - BDV 180°C (class H)

MOULDING AND BOBBIN ARE MADE BY 100% VIRGIN MATERIAL.

Max. allowable pressure (PS) 25 bar
Temperature ambiante: - 40°C + 80°C



Gaskets	Temperature		Medium
T=PTFE (polytetrafluorethylen)	- 40°C	+180°C	Steam, hot water

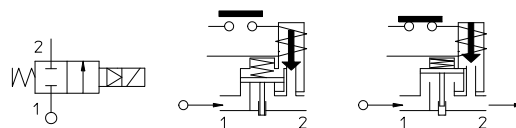

Pipe ANSI/ASME BI.20.1	Code	Max viscosity		Ø mm	Kv l/mn	Power (watt)	Pressure		
		cSt	°E				min	M.O.P.D.	
							bar	AC bar	DC bar
1/2 NPT	21YN4K0T130-YW	-	-	13	50	8	0,9	10	10
3/4 NPT	21YN5K0T190-YW			19	90				
1 NPT	21YN6K0T250-YW			25	160				

Note.

Available on request and with minimum quantities.

The "ODE" reserves the right to carry out technical and aesthetic modifications without prior notification.

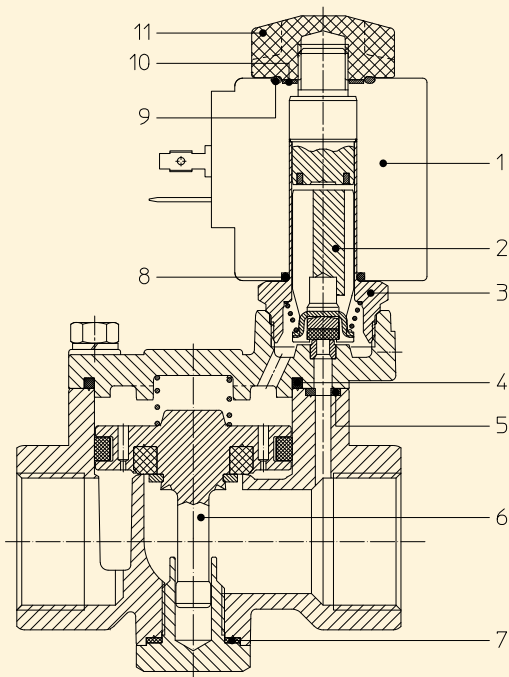

MATERIALS:

- Body** Brass - UNI EN 12165 CW617N
- Armature tube** Stainless steel AISI series 300
- Fixed core** Stainless steel AISI series 400
- Plunger** Stainless steel AISI series 400
- Phase displacement ring** Copper - Cu 99,9%
- Spring** Stainless steel AISI series 300
- Piston seal** Modified PTFE
- Main seal** Glassfiber reinforced T=PTFE
- Pilot seal** PTFE
- Orifice** Brass - UNI EN 12165 CW617N

On request:

- Connector** Pg 9 o Pg 11
- Connector conformity** ISO 4400

FEATURES:

- Electrical conformity** IEC 335
- Protection degree** IP 67 EN 60529 (DIN 40050)
with coil fitted by connector dedicated

SPARE PARTS:

- 1. Coil:** 3/4 NPT Code R452547
See coils list 1 NPT Code R452548
- 2. Complete plunger:** Code R450897
- 3. Complete armature tube:** 3/4÷ 1 NPT Code R452553
Code R450606
- 4. Sealing ring:** 1/2 NPT Code R452607
3/4 NPT Code R452551
1 NPT Code R452552
- 5. Gasket cover:** 1/2 NPT Code R452608
3/4÷ 1 NPT Code R450858
- 6. Complete piston:** 1/2 NPT Code R452604
- 7. Gasket plug:** 1/2 NPT Code R452609
3/4÷ 1 NPT Code R452553

KIT:

KT130KT30-AGP=**2+3+8+9+10+11**

MAINTENANCE KIT:

- 1/2NPTKTPYW4K0T13=**2+4+5+6+7**
- 3/4NPTKTPYW5K0T19=**2+4+5+6+7**
- 1 NPT KTPYW6K0T25=**2+4+5+6+7**

DIMENSIONS:

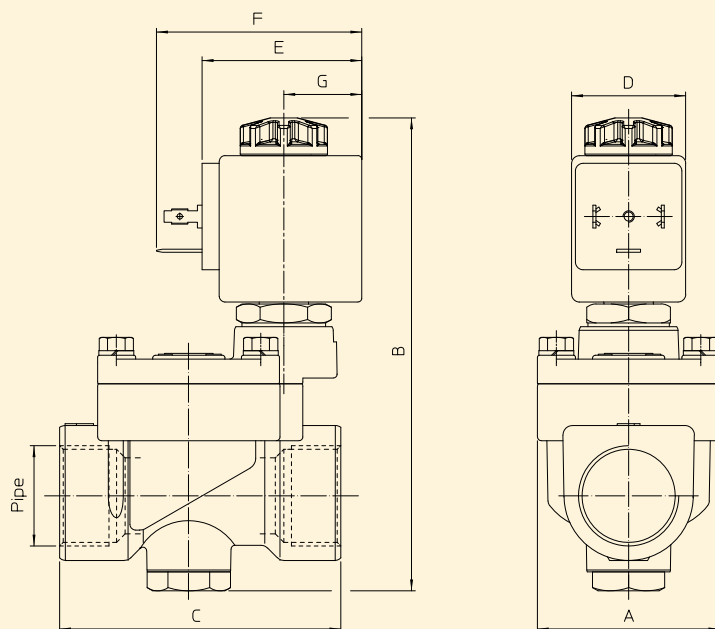

Type	Pipe	A mm	B mm	C mm
21YN4K0T130-YW	1/2 NPT	40	107	65
21YN5K0T190-YW	3/4 NPT	48	120	74
21YN6K0T250-YW	1 NPT	62	130	93

COIL TYPE	POWER ABSORPTION	DIMENSIONS			
	W	D mm	E mm	F mm	G mm
B	8	30	42	54	20,5



Solenoid valve 2/2 way N.O. With piston pilot control

21YW4Z0T130

÷

21YW6Z0T250

PRESENTATION:

S.V. with pilot control for interception of fluids compatible with the construction materials.

A minimum operational pressure of 0,9 bar is required.

The materials used and the tests carried out ensure maximum reliability and duration.

USE: Hot water, Steam

PIPES: G 1/2 - G 1

COIL: 8W - Ø 13
BDF - BDV 180°C (class H)

MOULDING AND BOBBIN ARE MADE BY 100% VIRGIN MATERIAL.

Max. allowable pressure (PS) 25 bar
Temperature ambiante: - 40°C + 80°C



Gaskets	Temperature		Medium
T=PTFE (polytetrafluorethylen)	- 40°C	+180°C	Steam, hot water

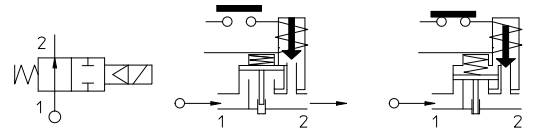

Pipe ISO 228/1	Code	Max viscosity		Ø mm	Kv l/mn	Power (watt)	Pressure		
		cSt	°E				min bar	M.O.P.D. AC bar DC bar	
G 1/2	21YW4Z0T130	-	-	13	50	8	0,9	10	10
G 3/4	21YW5Z0T190			19	90				
G 1	21YW6Z0T250			25	160				

Note.

Available on request and with minimum quantities.

The "ODE" reserves the right to carry out technical and aesthetic modifications without prior notification.

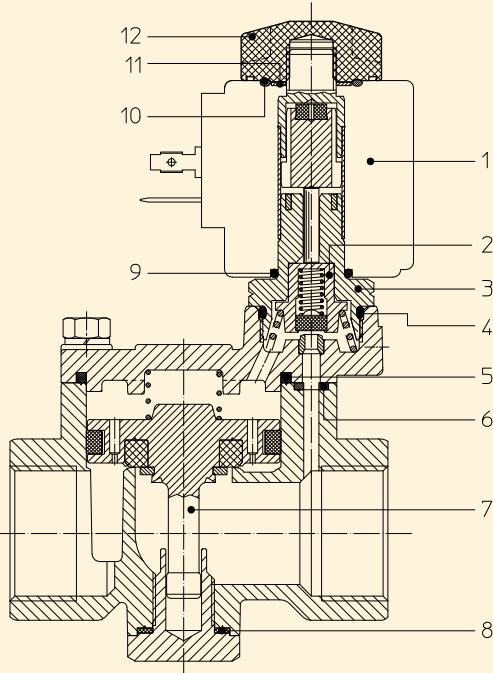

MATERIALS:

Body Brass - UNI EN 12165 CW617N
Armature tube Stainless steel AISI series 300
Fixed core Stainless steel AISI series 400
Plunger Stainless steel AISI series 400
Phase displacement ring Copper - Cu 99,9%
Spring Stainless steel AISI series 300
Piston seal Modified PTFE
Main seal Glassfiber reinforced T=PTFE
Pilot seal PTFE
Orifice Brass - UNI EN 12165 CW617N

On request:

Connector Pg 9 o Pg 11
Connector conformity ISO 4400

FEATURES:

Electrical conformity IEC 335
Protection degree IP 67 EN 60529 (DIN 40050)
 with coil fitted by connector dedicated

SPARE PARTS:

- 1. Coil:** See coils list G 3/4+G 1 Code R450858
- 2. Diaphragm support:** Code R450790 G 1/2 Code R452604
G 3/4 Code R452547
G 1 Code R452548
- 3. Complete armature tube without gasket:** Code R450573
- 4. Gasket O-Ring:** Code 990000/T
- 5. Sealing ring:** G 1/2 Code R452607
G 3/4 Code R452551
G 1 Code R452552
- 6. Gasket cover:** G 1/2 Code R452608
- 7. Complete piston:** G 1/2 Code R452604
G 3/4 Code R452547
G 1 Code R452548
- 8. Gasket plug:** G 1/2 Code R452609
G 3/4+G 1 Code R452553

KIT:

KT130ZT30-TG=2+3+4+9+10+11+12

MAINTENANCE KIT:

G 1/2 KTPYW4Z0T13=2+5+6+7+8
 G 3/4 KTPYW5Z0T19=2+5+6+7+8
 G 1 KTPYW6Z0T25=2+5+6+7+8

DIMENSIONS:

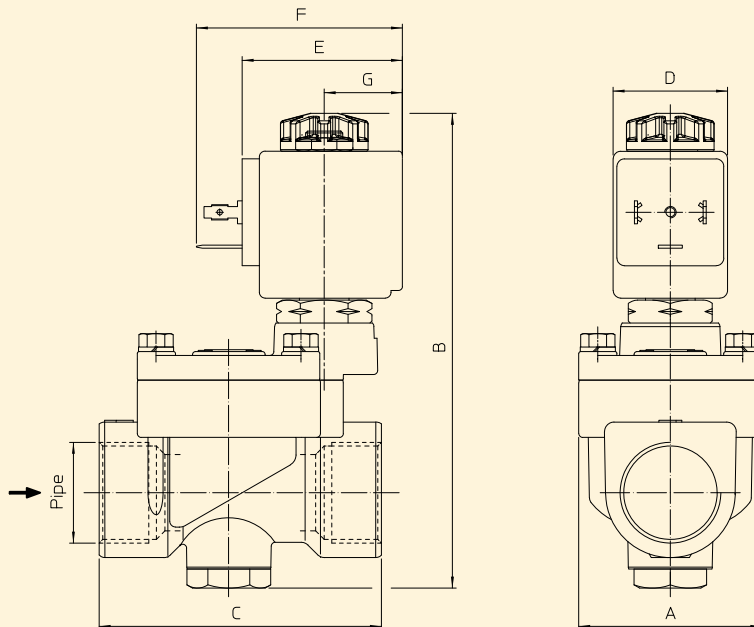

Type	Pipe ISO 228/1	A mm	B mm	C mm
21YW4Z0T130	G 1/2	40	107	65
21YW5Z0T190	G 3/4	48	120	74
21YW6Z0T250	G 1	62	130	93

COIL TYPE	POWER ABSORPTION	DIMENSIONS			
	W	D mm	E mm	F mm	G mm
B	8	30	42	54	20,5



Solenoid valve 2/2 way N.O. With piston pilot control

21YN4Z0T130-YW

÷

21YN6Z0T250-YW

PRESENTATION:

S.V. with pilot control for interception of fluids compatible with the construction materials.

A minimum operational pressure of 0,9 bar is required.

The materials used and the tests carried out ensure maximum reliability and duration.

USE: Hot water, Steam

PIPES: 1/2 NPT - 1 NPT

COIL: 8W - Ø 13
BDF - BDV 180°C (class H)

MOULDING AND BOBBIN ARE MADE BY 100% VIRGIN MATERIAL.

Max. allowable pressure (PS) 25 bar
Temperature ambiante: - 40°C + 80°C



Gaskets	Temperature		Medium
T=PTFE (polytetrafluorethylen)	- 40°C	+180°C	Steam, hot water

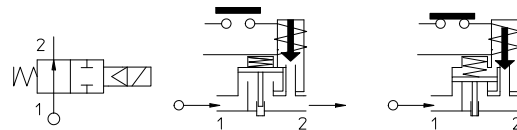

Pipe ANSI/ASME BI.20.1	Code	Max viscosity		Ø mm	Kv l/mn	Power (watt)	Pressure		
		cSt	°E				min	M.O.P.D.	
							bar	AC bar	DC bar
1/2 NPT	21YN4Z0T130-YW	-	-	13	50	8	0,9	10	10
3/4 NPT	21YN5Z0T190-YW			19	90				
1 NPT	21YN6Z0T250-YW			25	160				

Note.

Available on request and with minimum quantities.

The "ODE" reserves the right to carry out technical and aesthetic modifications without prior notification.

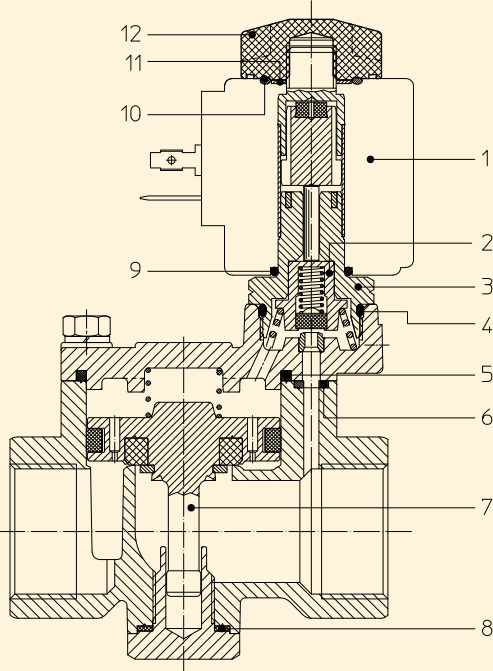

MATERIALS:

- Body** Brass - UNI EN 12165 CW617N
- Armature tube** Stainless steel AISI series 300
- Fixed core** Stainless steel AISI series 400
- Plunger** Stainless steel AISI series 400
- Phase displacement ring** Copper - Cu 99,9%
- Spring** Stainless steel AISI series 300
- Piston seal** Modified PTFE
- Main seal** Glassfiber reinforced T=PTFE
- Pilot seal** PTFE
- Orifice** Brass - UNI EN 12165 CW617N

On request:

- Connector** Pg 9 o Pg 11
- Connector conformity** ISO 4400

FEATURES:

- Electrical conformity** IEC 335
- Protection degree** IP 67 EN 60529 (DIN 40050)
with coil fitted by connector dedicated

SPARE PARTS:

- 1. Coil:**
See coils list
- 2. Diaphragm support:**
Code R450790
- 3. Complete armature tube without gasket:**
Code R450573
- 4. Gasket O-Ring:**
Code 990000/T
- 5. Sealing ring:**
NPT 1/2 Code R452607
NPT 3/4 Code R452551
NPT 1 Code R452552
- 6. Gasket cover:**
NPT 1/2 Code R452608
NPT 3/4+ 1 Code R450858
- 7. Complete piston:**
NPT 1/2 Code R452604
NPT 3/4 Code R452547
NPT 1 Code R452548
- 8. Gasket plug:**
NPT 1/2 Code R452609
NPT 3/4+ 1 Code R452553

KIT:

KT130ZT30-TG=2+3+4+9+10+11+12

MAINTENANCE KIT:

- 1/2 NPT KTPYW4Z0T13=2+5+6+7+8
- 3/4 NPT KTPYW5Z0T19=2+5+6+7+8
- 1 NPT KTPYW6Z0T25=2+5+6+7+8

DIMENSIONS:

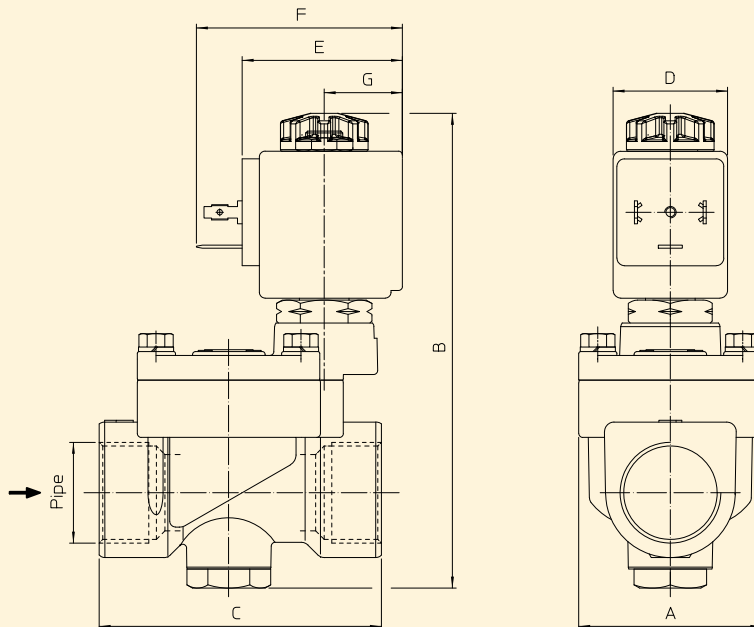

Type	Pipe	A mm	B mm	C mm
21YN4Z0T130-YW	1/2 NPT	40	107	65
21YN5Z0T190-YW	3/4 NPT	48	120	74
21YN6Z0T250-YW	1 NPT	62	130	93

COIL TYPE	POWER ABSORPTION	DIMENSIONS			
	W	D mm	E mm	F mm	G mm
B	8	30	42	54	20,5