



**Valve 2/2 way - angle seat/process valve
Normally Closed - Flow direction below
the seat - pneumatically operated**

21IA4T15GC2

÷

21IA9T50GC2

PRESENTATION:

- High flow rate due to the angle seat configuration.
- Anti-water hammer feature with the fluid entry below the seat.
- Electrical operation is easy with the addition of a solenoid pilot.
- Stainless steel body and corrosion resistant actuator.
- The pneumatic actuator can be rotated through 360 degrees.
- Optical position indicator.
- Internal seals are self adjusting for long life.
- Easily convertible from N.C. to N.O. or double acting.
- Universal mounting - any mounting orientation is acceptable.

USE: Automation, Heating, Water, Hot water, Steam (180°C), Aggressive and food fluids

PIPES: G 1/2 - G 2

VALVE FEATURES:

Fluid Temperature - 10°C + 180°C
 Ambient temperature - 10°C + 60°C
 Material Stainless steel AISI series 316
 Seal PTFE
 Packing gland PTFE, FKM

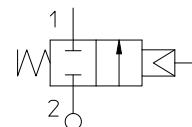

PILOT ACTUATOR FEATURES:

Fluid Dry Air or lubricated, gas and neutral fluids
 Fluid Temperature max + 60°C
 Body Polyamide 66 with 30% glass fibre
 Gaskets NBR
 Actuator Ø 70

Pipe ISO 228/1	Code	Ø mm	Kv l/mn	Actuator pilot pressure (bar)		Differential pressure (bar)		Max. allowable pressure PS (bar)	Weight Kg
				min	max	min	max		
G 1/2	21IA4T15GC2	15	80	4	10	0	16	40	1,4
G 3/4	21IA5T20GC2	20	150				10		1,5
G 1	21IA6T25GC2	25	190				10		1,8
G 1 1/4	21IA7T32GC2	32	340				7	25	2,4
G 1 1/2	21IA8T40GC2	40	430				4,5		2,7
G 2	21IA9T50GC2	50	620				3	16	3,9



CE Approval

(Pressure Equipment Directive 97/23/CE)

for Valve 21IA7 ÷ 21IA9

Note

Available on request pilot S.V. 31A2AV20+BDA (see catalogue page)
 Together with male thread nipple male G 1/4 - G 1/4
 Material compatibility with the fluids to be checked.

The "ODE" reserves the right to carry out technical and aesthetic modifications without prior notification.

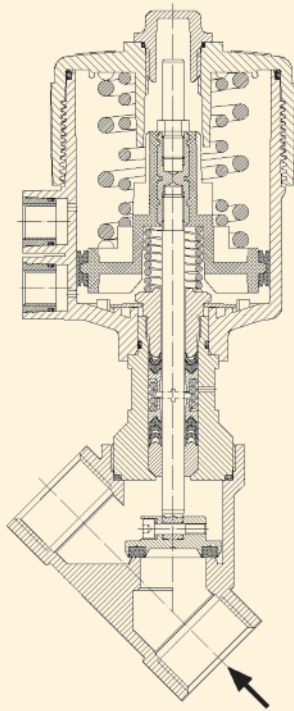

DIMENSIONS:

Pipe ISO 228/1	A mm	B mm	C mm	D mm	H mm	L mm	T mm
G 1/2	206,8	SW 27	178,7	15,4	163,3	65	17
G 3/4	211,7	SW 32	188,6	21,9	166,7	75,5	19
G 1	220,1	SW 41	197,8	25,1	172,7	90	21
G 1 1/4	235,9	SW 50	212,3	28,5	183,8	110	24
G 1 1/2	238,9	SW 55	217,0	31,0	186	122	25,2
G 2	247,8	SW 70	229,7	37,5	192,2	151	28,5

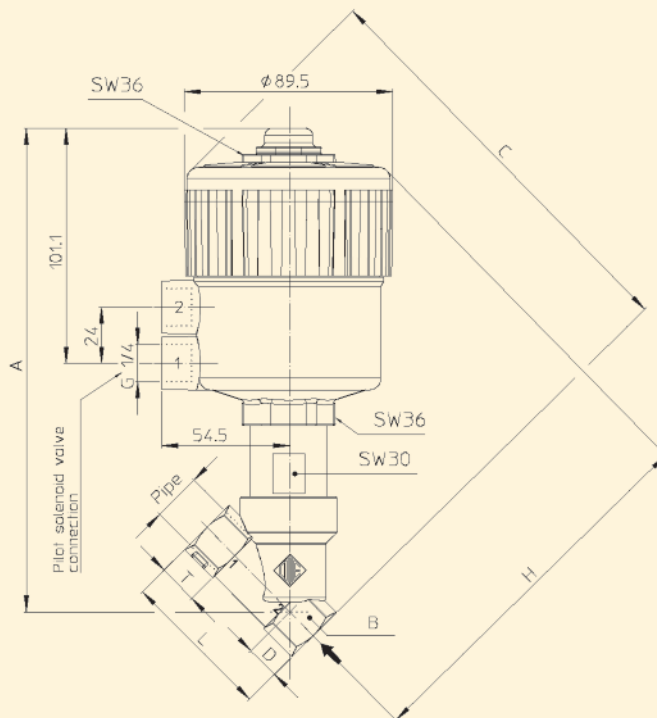



**Valve 2/2 way - angle seat/process valve
N.C. - Flow direction below the seat -
pneumatically operated**

**21IA4T15NC2
÷
21IA9T50NC2**

PRESENTATION:

- High flow rate due to the angle seat configuration.
- Anti-water hammer feature with the fluid entry below the seat.
- Electrical operation is easy with the addition of a solenoid pilot.
- Stainless steel body and corrosion resistant actuator.
- The pneumatic actuator can be rotated through 360 degrees.
- Optical position indicator.
- Internal seals are self adjusting for long life.
- Easily convertible from N.C. to N.O. or double acting.
- Universal mounting - any mounting orientation is acceptable.

USE: Automation, Heating, Water, Hot water, Steam (180°C), Aggressive and food fluids

PIPES: 1/2 NPT - 2 NPT

VALVE FEATURES:

Fluid Temperature	- 10°C + 180°C
Ambient temperature	- 10°C + 60°C
Material	Stainless steel AISI series 316
Seal	PTFE
Packing gland	PTFE, FKM

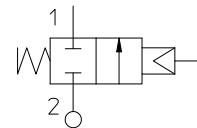

PILOT ACTUATOR FEATURES:

Fluid	Dry Air or lubricated, gas and neutral fluids
Fluid Temperature	max + 60°C
Body	Polyamide 66 with 30% glass fibre
Gaskets	NBR
Actuator	Ø 70

Pipe ANSI/ASME BI.20.1	Code	Ø mm	Kv l/mn	Actuator pilot pressure (bar)		Differential pressure (bar)		Max. allowable pressure PS (bar)	Weight Kg
				min	max	min	max		
1/2 NPT	21IA4T15NC2	15	80	4	10	0	16	40	1,4
3/4 NPT	21IA5T20NC2	20	150				10		1,5
1 NPT	21IA6T25NC2	25	190				10		1,8
1 1/4 NPT	21IA7T32NC2	32	340				7	25	2,4
1 1/2 NPT	21IA8T40NC2	40	430				4,5		2,7
2 NPT	21IA9T50NC2	50	620				3	16	3,9



CE Approval

(Pressure Equipment Directive 97/23/CE)

for Valve 21IA7 ÷ 21IA9

Note

Available on request pilot S.V. 31A2AV20+BDA (see catalogue page)
Together with male thread nipple male 1/4 NPT - 1/4 NPT
Material compatibility with the fluids to be checked.

The "ODE" reserves the right to carry out technical and aesthetic modifications without prior notification.

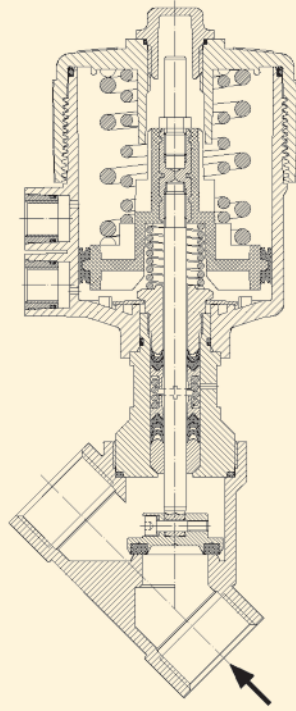

DIMENSIONS:

Pipe ANSI/ASME Bl.20.1	A mm	B mm	C mm	D mm	H mm	L mm	T mm
1/2 NPT	206,8	SW 27	178,7	15,4	163,3	65	17
3/4 NPT	211,7	SW 32	188,6	21,9	166,7	75,5	19
1 NPT	220,1	SW 41	197,8	25,1	172,7	90	21
1 1/4 NPT	235,9	SW 50	212,3	28,5	183,8	110	24
1 1/2 NPT	238,9	SW 55	217,0	31,0	186	122	25,2
2 NPT	247,8	SW 70	229,7	37,5	192,2	151	28,5

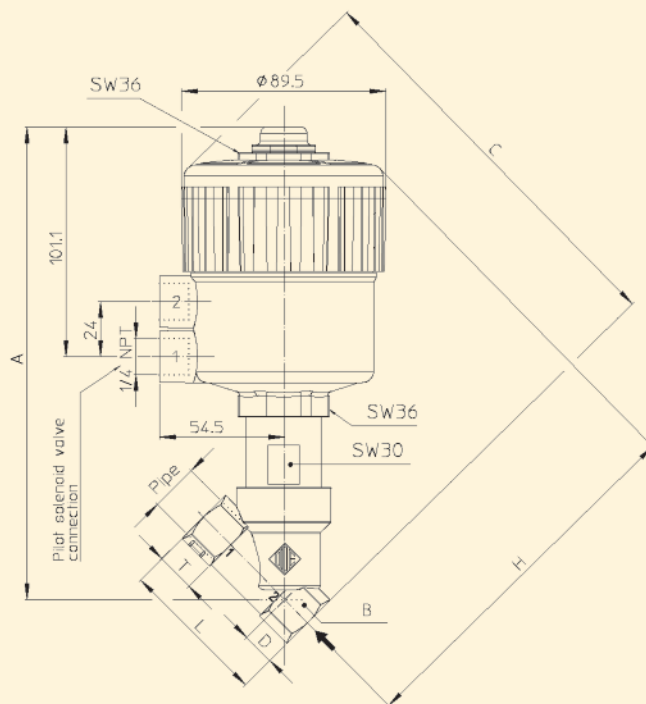



Valve 2/2 way - angle seat/process valve
Normally Open - Flow direction below
the seat - pneumatically operated

21IA4T15GA2
÷
21IA9T50GA2

PRESENTATION:

- High flow rate due to the angle seat configuration.
- Anti-water hammer feature with the fluid entry below the seat.
- Electrical operation is easy with the addition of a solenoid pilot.
- Stainless steel body and corrosion resistant actuator.
- The pneumatic actuator can be rotated through 360 degrees.
- Optical position indicator.
- Internal seals are self adjusting for long life.
- Easily convertible from N.C. to N.O. or double acting.
- Universal mounting - any mounting orientation is acceptable.

USE: Automation, Heating, Water, Hot water, Steam (180°C), Aggressive and food fluids

PIPES: G 1/2 - G 2

VALVE FEATURES:

Fluid Temperature - 10°C + 180°C
 Ambient temperature - 10°C + 60°C
 Material Stainless steel AISI series 316
 Seal PTFE
 Packing gland PTFE, FKM

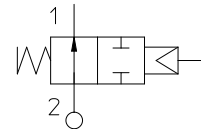

PILOT ACTUATOR FEATURES:

Fluid Dry Air or lubricated, gas and neutral fluids
 Fluid Temperature max + 60°C
 Body Polyamide 66 with 30% glass fibre
 Gaskets NBR
 Actuator Ø 70

Pipe ISO 228/1	Code	Ø mm	Kv l/mn	Actuator pilot pressure (bar)		Differential pressure (bar)		Max. allowable pressure PS (bar)	Weight Kg
				min	max	min	max		
G 1/2	21IA4T15GA2	15	80	1,5	10	0	(See pressure graph)	40	1,2
G 3/4	21IA5T20GA2	20	150						1,3
G 1	21IA6T25GA2	25	190						1,6
G 1 1/4	21IA7T32GA2	32	340					25	2,2
G1 1/2	21IA8T40GA2	40	430						2,5
G 2	21IA9T50GA2	50	620						3,7



CE Approval

(Pressure Equipment Directive 97/23/CE)

for Valve 21IA7 ÷ 21IA9

Note

Available on request pilot S.V. 31A2AV20+BDA (see catalogue page)
 Together with male thread nipple male G 1/4 - G 1/4
 Material compatibility with the fluids to be checked.

The "ODE" reserves the right to carry out technical and aesthetic modifications without prior notification.

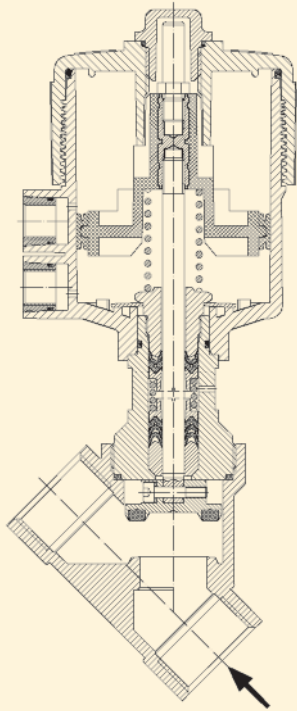

Operating pressure

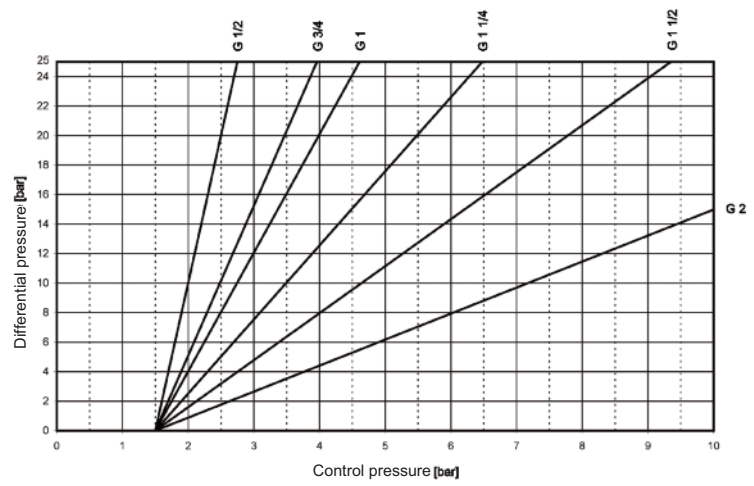

DIMENSIONS:

Pipe ISO 228/1	A mm	B mm	C mm	D mm	H mm	L mm	T mm
G 1/2	206,8	SW 27	178,7	15,4	163,3	65	17
G 3/4	211,7	SW 32	188,6	21,9	166,7	75,5	19
G 1	220,1	SW 41	197,8	25,1	172,7	90	21
G 1 1/4	235,9	SW 50	212,3	28,5	183,8	110	24
G 1 1/2	238,9	SW 55	217,0	31,0	186	122	25,2
G 2	247,8	SW 70	229,7	37,5	192,2	151	28,5

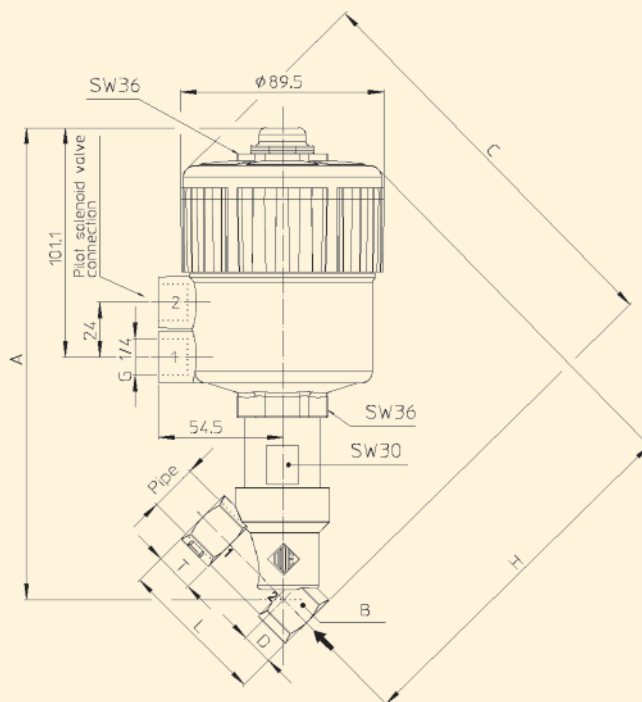



Valve 2/2 way - angle seat/process valve
N.O. - Flow direction below the seat -
pneumatically operated

21IA4T15NA2
÷
21IA9T50NA2

PRESENTATION:

- High flow rate due to the angle seat configuration.
- Anti-water hammer feature with the fluid entry below the seat.
- Electrical operation is easy with the addition of a solenoid pilot.
- Stainless steel body and corrosion resistant actuator.
- The pneumatic actuator can be rotated through 360 degrees.
- Optical position indicator.
- Internal seals are self adjusting for long life.
- Easily convertible from N.C. to N.O. or double acting.
- Universal mounting - any mounting orientation is acceptable.

USE: Automation, Heating, Water, Hot water, Steam (180°C), Aggressive and food fluids

PIPES: 1/2 NPT - 2 NPT

VALVE FEATURES:

Fluid Temperature - 10°C + 180°C
 Ambient temperature - 10°C + 60°C
 Material Stainless steel AISI series 316
 Seal PTFE
 Packing gland PTFE, FKM

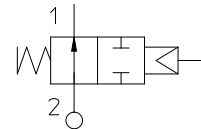

PILOT ACTUATOR FEATURES:

Fluid Dry Air or lubricated, gas and neutral fluids
 Fluid Temperature max + 60°C
 Body Polyamide 66 with 30% glass fibre
 Gaskets NBR
 Actuator Ø 70

Pipe ANSI/ASME BI.20.1	Code	Ø mm	Kv l/mn	Actuator pilot pressure (bar)		Differential pressure (bar)		Max. allowable pressure PS (bar)	Weight Kg
				min	max	min	max		
1/2 NPT	21IA4T15NA2	15	80	1,5	10	0	(See pressure graph)	40	1,2
3/4 NPT	21IA5T20NA2	20	150						1,3
1 NPT	21IA6T25NA2	25	190						1,6
1 1/4 NPT	21IA7T32NA2	32	340					25	2,2
1 1/2 NPT	21IA8T40NA2	40	430						2,5
2 NPT	21IA9T50NA2	50	620						3,7



CE Approval
 (Pressure Equipment Directive 97/23/CE)
 for Valve 21IA7 ÷ 21IA9

Note

Available on request pilot S.V. 31A2AV20+BDA (see catalogue page)
 Together with male thread nipple male 1/4 NPT - 1/4 NPT
 Material compatibility with the fluids to be checked.

The "ODE" reserves the right to carry out technical and aesthetic modifications without prior notification.

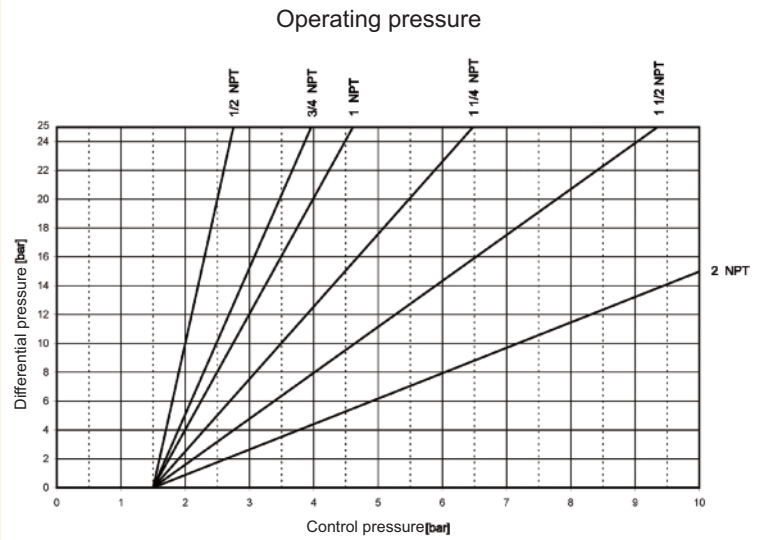
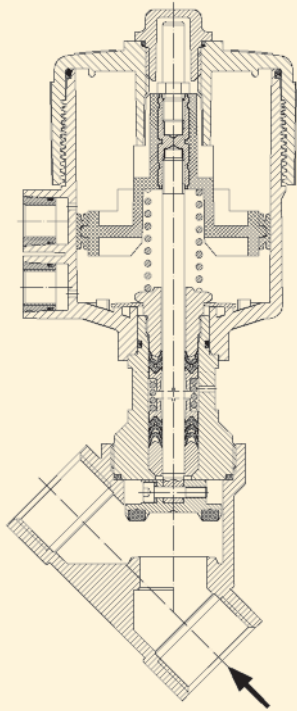

DIMENSIONS:

Pipe ANSI/ASME Bl.20.1	A mm	B mm	C mm	D mm	H mm	L mm	T mm
1/2 NPT	206,8	SW 27	178,7	15,4	163,3	65	17
3/4 NPT	211,7	SW 32	188,6	21,9	166,7	75,5	19
1 NPT	220,1	SW 41	197,8	25,1	172,7	90	21
1 1/4 NPT	235,9	SW 50	212,3	28,5	183,8	110	24
1 1/2 NPT	238,9	SW 55	217,0	31,0	186	122	25,2
2 NPT	247,8	SW 70	229,7	37,5	192,2	151	28,5

